

FRONT VIEW OF
PERFORATED "Z"
SUPPORT STRIP
20 OZ ~40% NET
FREE AREA

CRESTING
SEE DESIGN

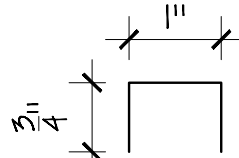

FRONT VIEW OF
SUPPORT BRACKET

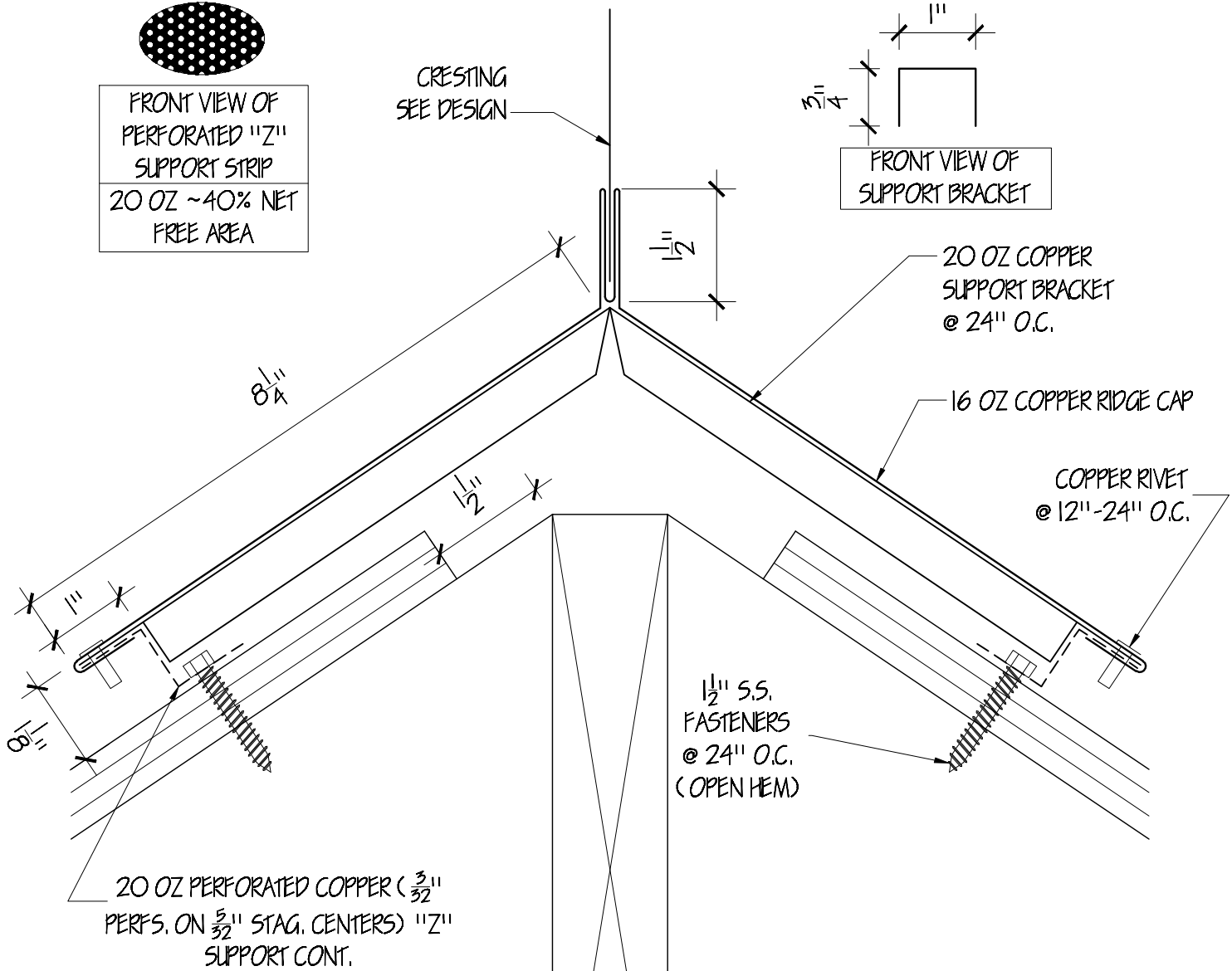

20 OZ COPPER
SUPPORT BRACKET
@ 24" O.C.

16 OZ COPPER RIDGE CAP

COPPER RIVET
@ 12"-24" O.C.

1/2" S.S.
FASTENERS
@ 24" O.C.
(OPEN HEM)

20 OZ PERFORATED COPPER (3/32"
PERFS. ON 5/32" STAG. CENTERS) "Z"
SUPPORT CONT.

Installation Instructions:

- Install "Z" strip on left and right sides of ridge, using 1/2" stainless steel screws to fasten to roof.
- Install support bracket at two farthest most ends, then space every 24" o.s., with one laying out on every ridge seam for support. (Recommended overlap of ridge cap is 3")
- Secure copper supports to "Z" strip with copper rivets (provided).
- Install copper ridge on supports.
- Open hem on ridge is accepted in copper "Z" strip, needs to be closed with hand seamers.
- Secure ridge to copper supports with copper rivets as necessary.
- Copper ridge will need to be turned down at gable ends for closure.

SIGNATURE:

DATE:



OLD WORLD DISTRIBUTORS, INC.

Available Materials:

- 24 ga. Galvalume 16 oz. Copper
- 24 ga. Kynar Steel 16 oz. Freedom Gray
- .040 Kynar Aluminum Copper
- 24 ga. Zinc

Notes:

Part No.: Vented Cresting Ridge - Large CR-L